

6.5.7 Type VL 090 – Type V with flange for motor mounting

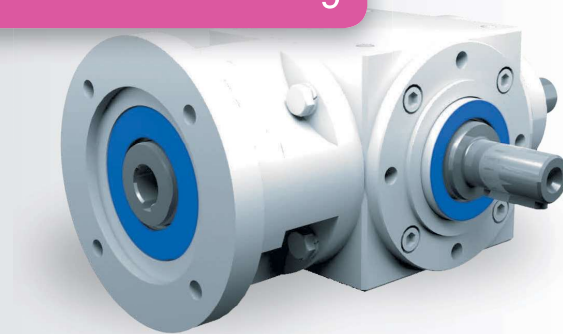

Characteristics

Characteristic	Standard	Option
Toothing	Bevel gear set, spiral-toothed	See chapter 6.2.1
Gear ratio	1:1 to 6:1	
Housing / Flanges	Grey cast iron	
Threaded mounting hole	On all housing surfaces without flange and on all flanges.	See chapter 6.2.3
Shaft	Material 1 C45, shaft ends greased Fit with ISO 6 tolerance with parallel keyway: according to DIN 6885 Sheet 1	See chapter 4.6.2
Hollow shaft	Material 1 C45, shafts greased Fit with ISO 7 tolerance with parallel keyway: according to DIN 6885 Sheet 1	See chapter 4.6.3
Radial shaft seal ring	NBR, form A	See chapter 4.8
Ambient temperature	-10°C to +90°C. The values of the performance tables are valid for +20°C	See chapter 4.9.3
Circumferential backlash	< 30 arcmin	See chapter 6.2.10
Protection class	IP 54	See chapter 4.5
Corrosion protection	Prime coat; layer thickness > 40 µm	See chapter 4.4.1
Bearing life L10h	more than 15,000h	See chapter 4.9.1
Oil change intervals	Not required if the oil temperature is kept < 90°C The lifetime of the bearings can be increased by the factor 1.5 if the oil is changed after the first 500 service hours and then every 5000 service hours.	See chapter 6.2.8
Lubricants	Synthetic lubricants	See chapter 6.2.8
Flange	Suited for the mounting of IEC motors	
Coupling	Three-piece claw coupling	

Performance data

n ₁ [rpm]	1:1			1.5:1			2:1			3:1			4:1			5:1			6:1			
	n ₂ [rpm]	P _{1N} [kW]	T _{2N} [Nm]	n ₂ [rpm]	P _{1N} [kW]	T _{2N} [Nm]	n ₂ [rpm]	P _{1N} [kW]	T _{2N} [Nm]	n ₂ [rpm]	P _{1N} [kW]	T _{2N} [Nm]	n ₂ [rpm]	P _{1N} [kW]	T _{2N} [Nm]	n ₂ [rpm]	P _{1N} [kW]	T _{2N} [Nm]	n ₂ [rpm]	P _{1N} [kW]	T _{2N} [Nm]	
3000	3000	8.93	27	2000	5.51	25	1500	3.80	23	1000	2.54	23	750	1.90	23	600	1.52	23	500	1.25	23	
2400	2400	7.41	28	1600	4.59	26	1200	3.17	24	800	2.12	24	600	1.65	25	480	1.32	25	400	1.09	25	
1500	1500	5.29	32	1000	3.20	29	750	2.23	27	500	1.49	27	375	1.12	27	300	0.89	27	250	0.74	27	
1000	1000	3.75	34	667	2.35	32	500	1.71	31	333	1.14	31	250	0.85	31	200	0.68	31	167	0.53	29	
750	750	3.06	37	500	1.93	35	375	1.32	32	250	0.88	32	188	0.66	32	150	0.53	32	125	0.40	29	
500	500	2.20	40	333	1.36	37	250	0.94	34	167	0.63	34	125	0.47	34	100	0.37	34	83	0.27	29	
250	250	1.21	44	167	0.74	40	125	0.50	36	83	0.33	36	63	0.25	36	50	0.20	36	42	0.14	30	
50	50	0.28	50	33	0.16	45	25	0.10	37	17	0.07	37	13	0.05	37	10	0.04	37	8	0.03	33	
P _{1Nt} [kW]		3.8			3.8			3.8			3.8			3.8			3.8					
T _{2max} [Nm]		105			45			80			70			70			60			50		

Permissible radial force F_{r2} and axial force F_{a2} on shaft N₂

n ₂ [rpm]	3000		1000		500		250		100		50	
T _{2N} [Nm]	F _r [N]	F _a [N]	F _r [N]	F _a [N]	F _r [N]	F _a [N]	F _r [N]	F _a [N]	F _r [N]	F _a [N]	F _r [N]	F _a [N]
< 30	500	250	660	330	800	400	950	475	1250	625	1500	750
> 30	420	210	550	275	670	335	790	395	1040	520	1250	625

Inertia moments/mass

Inertia moment J₁ related to the fast-rotating shaft (N₁)

Model	Inertia moment [kgcm ²]						
	1:1	1.5:1	2:1	3:1	4:1	5:1	6:1
A0	2.88400	1.82740	1.48200	1.22120	1.15050	1.09920	1.09330
B0	3.67930	2.52850	1.70350	1.37930	1.24810	1.16770	1.13730
C0	3.67930	2.52850	1.70350	1.37930	1.24810	1.16770	1.13730
D0	3.70770	2.54110	1.71060	1.38240	1.24990	1.16890	1.13810
EON	3.57570	2.48240	1.67760	1.36780	1.24160	1.16360	1.13440
EOS	4.24630	2.78050	1.84520	1.44230	1.28350	1.19040	1.15310
FO	4.16350	2.39600	1.80190	1.36330	1.23040	1.15040	1.12890
GO	4.95880	3.44200	2.52730	2.12550	1.53120	1.44130	1.40800
HO	4.95880	3.44200	2.52730	2.12550	1.53120	1.44130	1.40800
JO	4.98720	3.45460	2.53440	2.12860	1.53300	1.44250	1.40880
KON	4.85520	3.39590	2.50140	2.11400	1.52470	1.43720	1.40510
KOS	5.52580	3.69400	2.66900	2.18850	1.56660	1.46110	1.42380

Mass [kg]
6.7
7.0
7.0
7.1
6.6
6.8
7.9
8.5
8.5
8.6
8.1
8.3

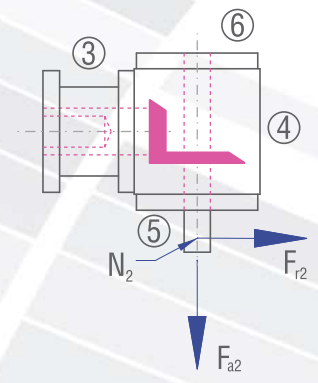

6.5.7 Type VL 090 – Type V with flange for motor mounting

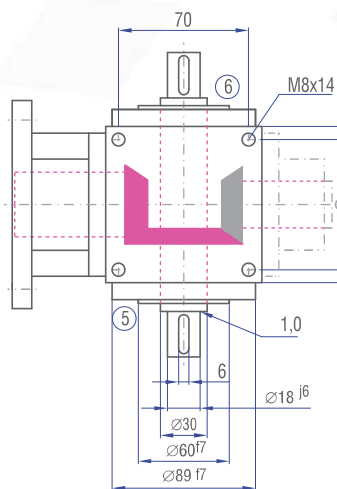
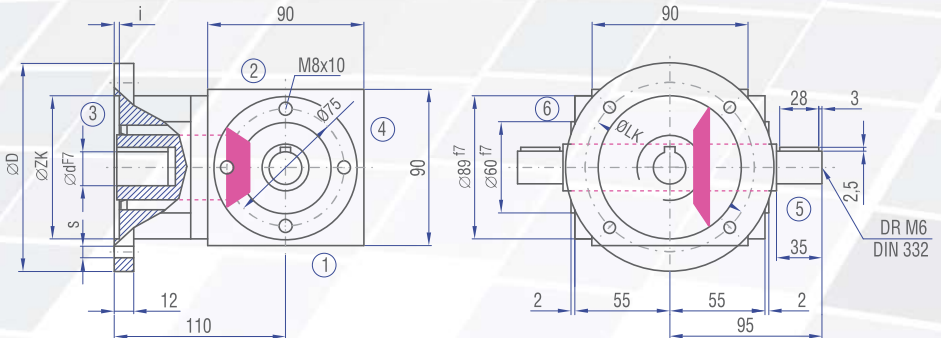
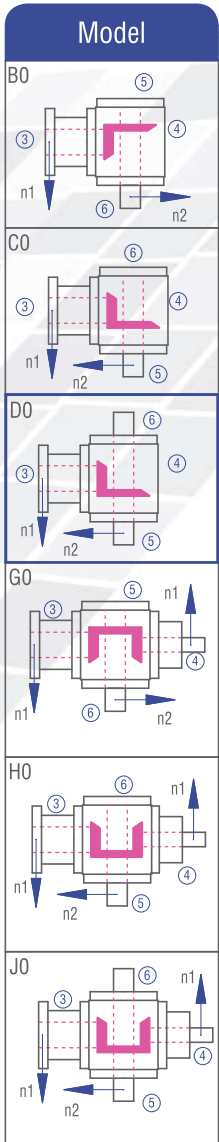
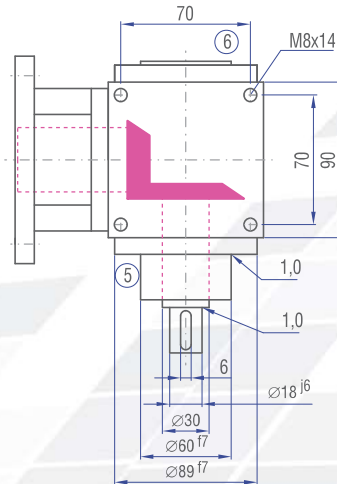
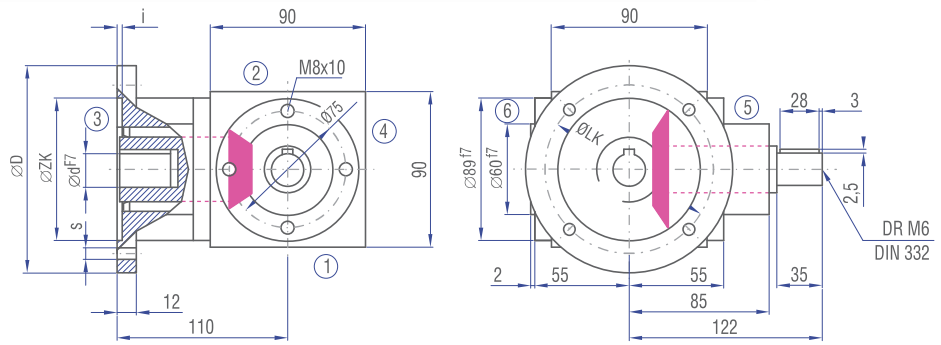
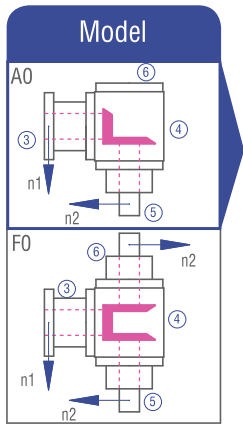

Implementation VV

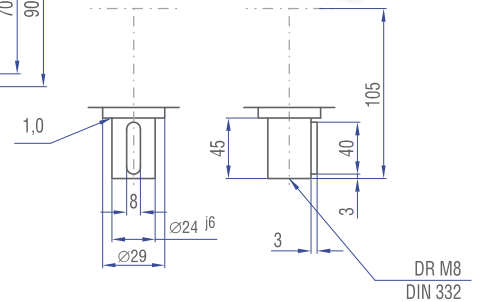

IEC motor	Model	Shaft (dxl)	D [mm]	LK [mm]	ZK [mm]	s [mm]	i [mm]
63	B14	11x23	120	100	80	7	3
	B5	11x23	140	115	95	9	3
71	B14	14x30	140	115	95	9	3
	B5	14x30	160	130	110	9	4
80	B14	19x40	120	100	80	7	3
	B14	19x40	160	130	110	9	4

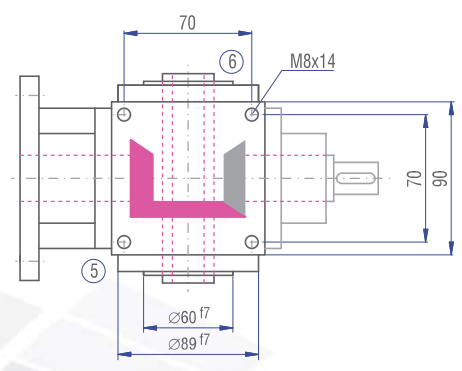
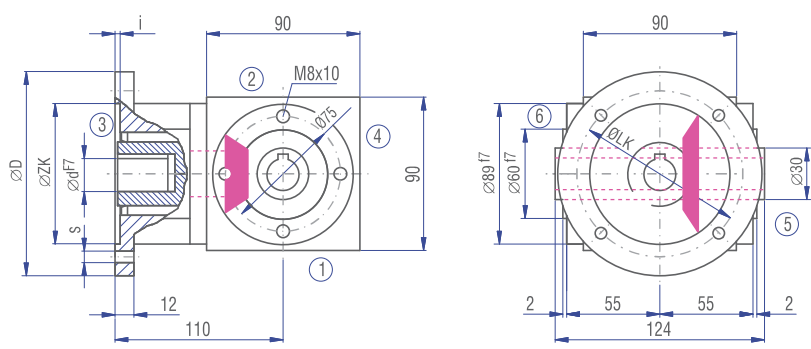

Implementation

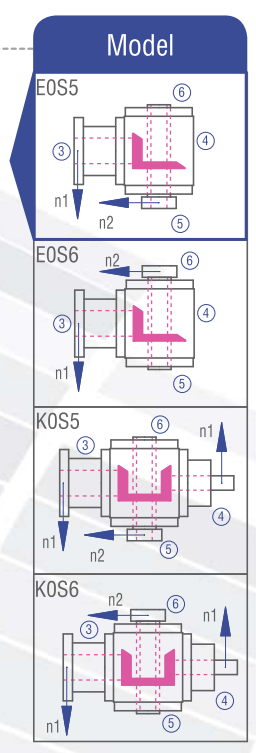
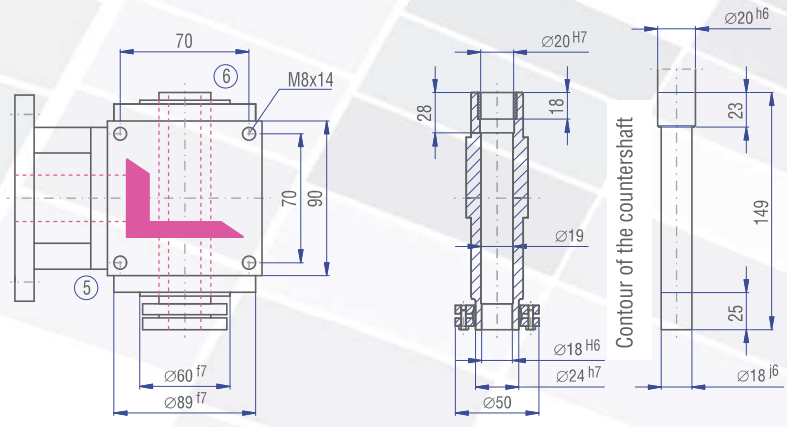
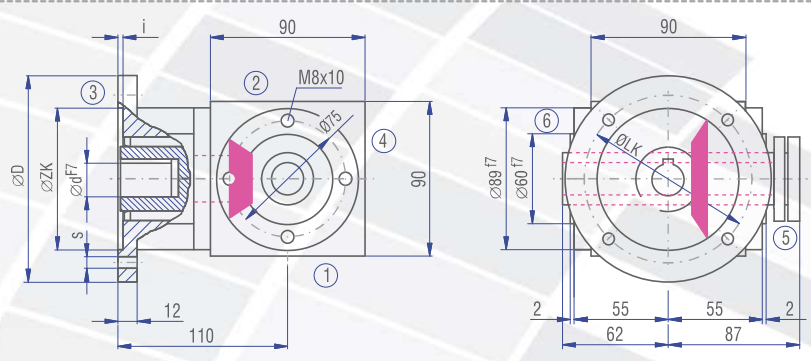
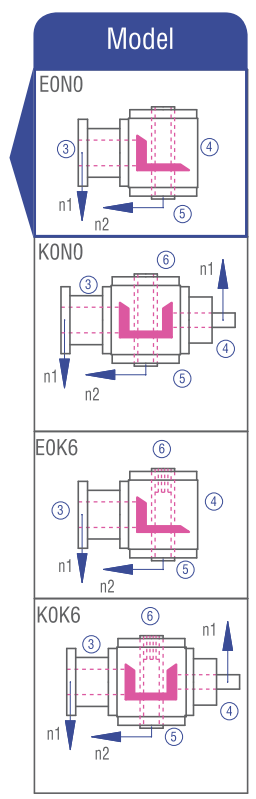
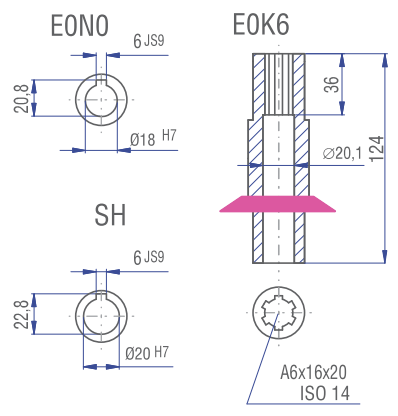

The dimensions of the Models not shown can be figured by mirroring available dimensions.
The shaft dimensions on side 4 follow from the dimensions of type A0.